

UNIMPROVED BNC ASSEMBLY INSTRUCTIONS

TED 4-10-124 + 4-10-32 + PC-441

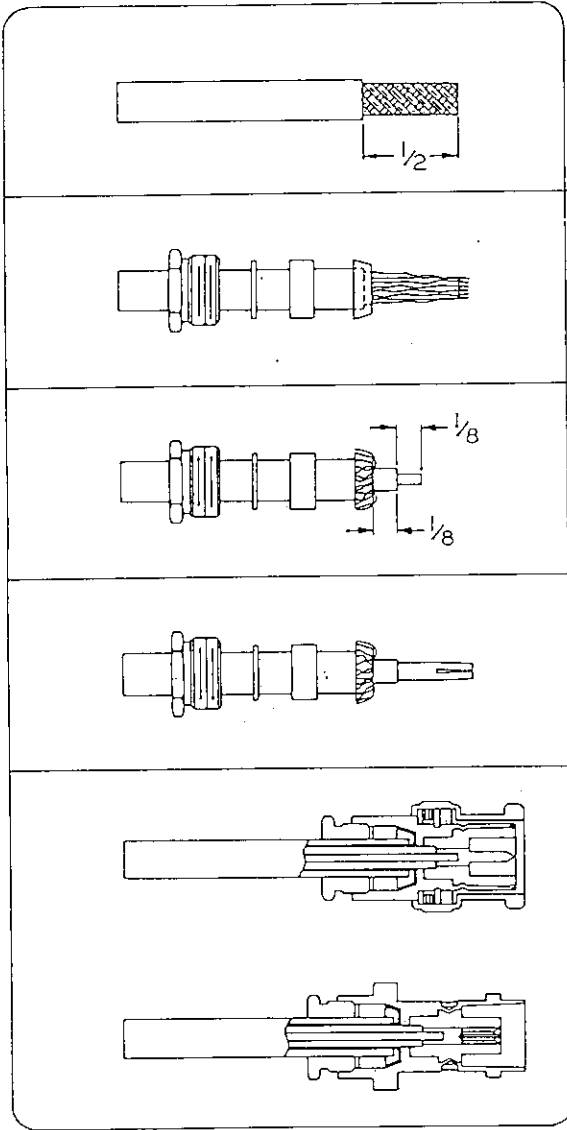
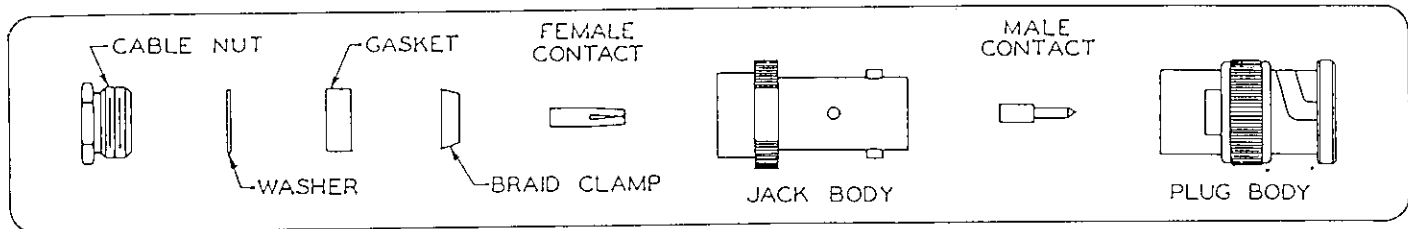

1. Cut cable off square and trim off outer jacket to dimension shown.

2. Comb out braid and taper over end of dielectric. Slide cable nut, washer and gasket over outer jacket of cable and position braid clamp as shown.

3. Fold braid back over braid clamp and trim off excess braid. Trim dielectric and center conductor to dimensions shown.

4. Solder contact to center conductor. Remove excess solder.

5. Insert assembly into connector body and tighten nut.